

## 8' Strip - (2-Lamp)

### Description

Carson's 72W linear 8' LED 2-lamp industrial strip emits 8,900 lumens with performance equal to replacement of 2-lamp F96 fluorescent fixture. Only available in three color temperatures, the stationary Fa8 end cap locks into single pin lampholder that runs directly off line voltage for the jack chain mount fixture. Ideal for applications such as plants, warehouses, and parking garages.

91% ROI

Annual Savings of \$41.00

13 month payback

Calculations are based on 4,380 annual hours of operation and \$0.12 average cost per kWh

Product #	Watts	Lumens	lm/W
CT-D02072FBN	72	8,964	124.5

### Luminous Intensity

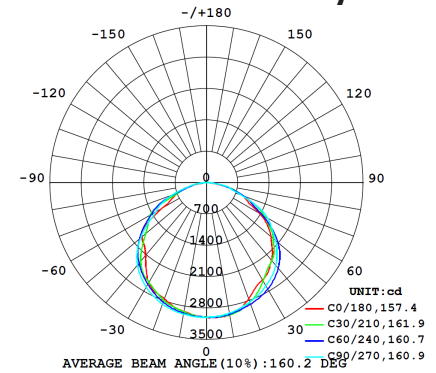

### Key Features

- Uses Epistar SMD2835 chip
- Rated for 50,000 hours
- 10 year warranty
- UL listing: E357799
- LED quantity: 384 chips
- Input voltage: AC 110V-277V
- Mounting: jack chains
- Frosted or clear polycarbonate lens
- White powder-coated aluminum fixture
- Built-in internal driver - bypass external ballast
- Stationary Fa8 power ends insert into single pin lampholder
- 1/2" knockouts on junction box for conduit electrical feed
- Wattstopper FSP 0-10V dimmable motion sensor & daylight harvesting
- Leviton on/off motion sensor add-on option



### Dimensions

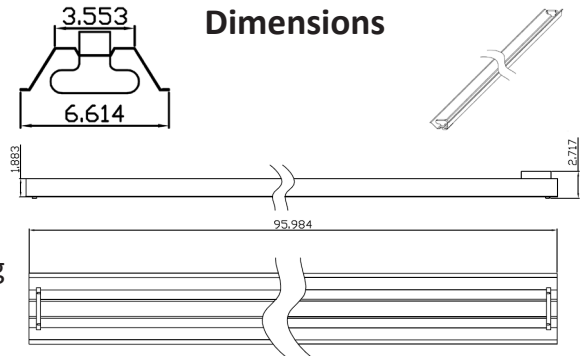

### Ordering Information: CT-D02072FBN

D	02	072	F	B	N	
Chip	Dimmable	Watts	Series	Type	Color	Options
D - DC	02 - Non-dimmable	072 - 72W/8 ft	F - Linear Strip	B - Clear F - Frosted	W - 3500K C - 4100K N - 5000K	DS - Dimmable Sensor OS - On/Off Sensor